

BAUM – Quality, Performance & Proven Reliability, with decades of experience

Optional Folding Enhancements

Baum Large Format Independent Folding Units

Baum offers multiple solutions to add additional folding stations to existing large format folding machines or for inline solutions with other finishing applications.

Other applications may include but are not limited to:

- In line with stitching machines
- In line with forms cutters and bursters
- In line with creasing/ scoring machines
- In line with digital print engines
- In line with mailing bases
- and more

Baum offers a selection of coupling modules to adapt the Baum buckle and knife folders to previous series Baum folders and select other models.



Specifications - Baum 32 with Continuous Feeder:

Maximum sheet size	32.28"W x 5039"L [82cm x 128cm]
Minimum sheet size	5.51"W x 7.09"L [14cm x 18cm]
Sheet blow	Front and side blow standard
Maximum folder speed	9055ipm [230m/min]
Fold roller diameter	1.73" [44mm]
Fold Roller style.....	Soft PU Full Combination
Slitter shaft design	Removable, adjustable center
Slitter shaft diameter	1.38" [35mm]
Fold Plates 1st section.....	4 or 6 [swing deflector]
2nd section	2, 4, 6 or 8 [swing deflector]
3rd section.....	2 or 4 [swing deflector]
Optional combination fold plates are available.	
Minimum fold length	1.75" [3.5cm]
Folder Drive.....	AC Inverter
Mechanical roller drive	Helical gear
Gear lubrication.....	Pressurized canisters
Bearings.....	Sealed ball bearings
Electrics	220/3/60

NOTE: Specifications subject to change without notice.

FOLDERS • CUTTERS • DRILLS • FINISHING • GENUINE PARTS

See us on the internet at <http://www.baumfolder.com> or e-mail us at baumfolder@baumfolder.com



1660 Campbell Road
Sidney OH 45365-0728

BAUM 32 Continuous Large Format Folder

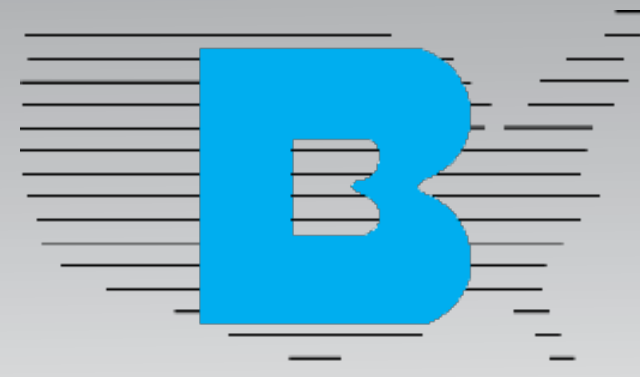

BAUM

FOLDERS • CUTTERS • DRILLS • PRESS • FINISHING • GENUINE PARTS

www.baumfolder.com



To locate an authorized Baum Dealer near you, call 1-800/543-6107 or your territory representative.

Since 1917, Baum has been designing, manufacturing and distributing quality folding machines and related bindery equipment to the industry. Baum has a proud tradition and rich history of incorporating innovative postpress technology in our complete product line. Baum has consistently lead with innovative features and patented designs to make us a world leader in graphic arts equipment. Baum provides the most productive and reliable folding machines on the market.

Baum 32 Folder Floor Layouts

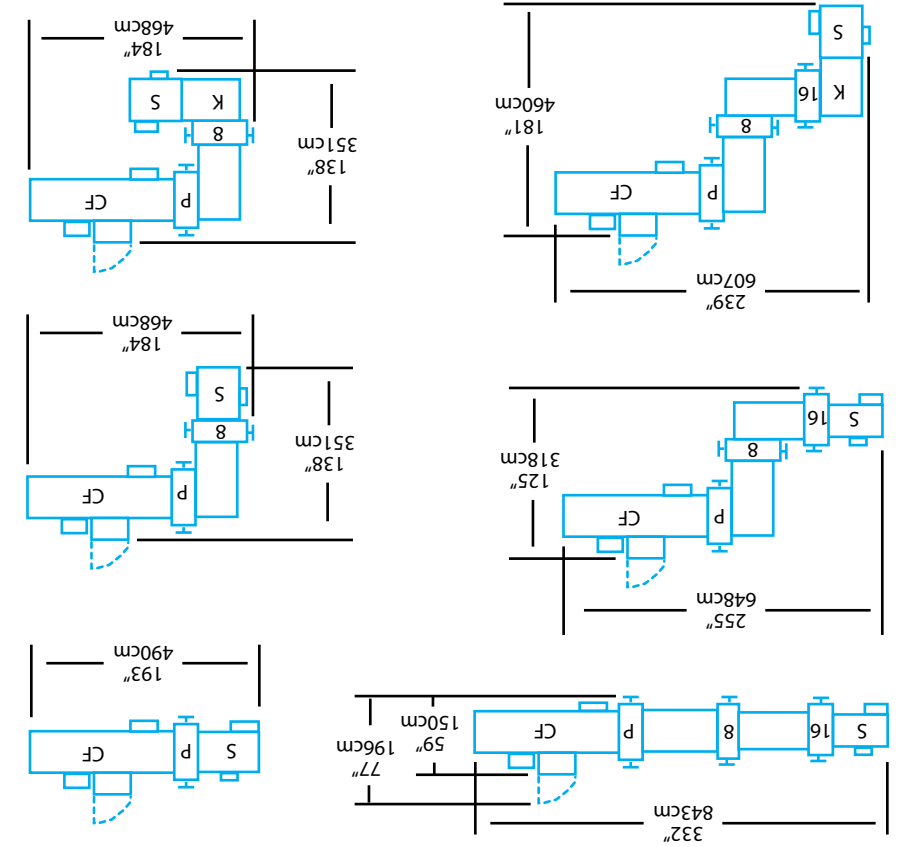

CF = Continuous Feeder
P = Parallel Folder
8 = 8-page Folder
16 = 16-page Folder
K = Knife Folder
S = Stacker-2 Tiered

Note: Feeder shown with control box door open/closed. Optional delivery systems not shown.

Baum B32 2-tiered Shingle Delivery Stacker: Mobile, with drop-leaf table, independent speed control, adjustable height and locking casters.



Baum BHP Horizontal Presser Delivery: This mobile device provides pressing and horizontal stacking of signatures to create "logs" or finished product. This delivery system can easily handle medium to large run lengths while also allowing a single operator to operate both the folding machine and the delivery system. The signatures are pressed, counted and delivered with the spine down. As many as four up stacking can be achieved depending upon the width of the final product.



Baum BVP Vertical Presser Delivery: This device is a mobile, very compact system that counts, patches presses and vertically stacks folded signatures or bound products by vertically creating a lift from the bottom up in as many as four up stacks. The convenient work table and infed table heights provide favorable ergonomics for the operator.



Baum BSP Shingle Presser Delivery: This delivery system is a universal, height adjustable, mobile shingle stream delivery that includes a pressing device. Conveyor belts accept the folded product from the previous fold station and send them through a set of pressing rollers. The pressed signatures are then output in a shingled stream for the operator to remove. The speed of the shingled stream is infinitely, independently adjustable.

Neutralizes the electric charges by creating an ionization field.

To slit folded 2-up sheets as they exit the parallel folder, then fold in the right angle folder as two separate streams on the same crosscarrier.

Helps hold signatures together for perfect-binding operations and saddle stitching.

Produces tighter folds and reduces cracking at the folded edge.

Increases folding capability by enabling the folder to produce a closed "double gatefold". This innovative pneumatic and electronic device operates at production speeds that are faster than all previous designs.

Increases folding capability by enabling the folder to produce a closed "double gatefold". This innovative pneumatic and electronic device operates at production speeds that are faster than all previous designs.

Increases folding capability by enabling the folder to produce a closed "double gatefold". This innovative pneumatic and electronic device operates at production speeds that are faster than all previous designs.

Increases folding capability by enabling the folder to produce a closed "double gatefold". This innovative pneumatic and electronic device operates at production speeds that are faster than all previous designs.

Increases folding capability by enabling the folder to produce a closed "double gatefold". This innovative pneumatic and electronic device operates at production speeds that are faster than all previous designs.

Increases folding capability by enabling the folder to produce a closed "double gatefold". This innovative pneumatic and electronic device operates at production speeds that are faster than all previous designs.

Increases folding capability by enabling the folder to produce a closed "double gatefold". This innovative pneumatic and electronic device operates at production speeds that are faster than all previous designs.

Increases folding capability by enabling the folder to produce a closed "double gatefold". This innovative pneumatic and electronic device operates at production speeds that are faster than all previous designs.

Increases folding capability by enabling the folder to produce a closed "double gatefold". This innovative pneumatic and electronic device operates at production speeds that are faster than all previous designs.

Increases folding capability by enabling the folder to produce a closed "double gatefold". This innovative pneumatic and electronic device operates at production speeds that are faster than all previous designs.

Increases folding capability by enabling the folder to produce a closed "double gatefold". This innovative pneumatic and electronic device operates at production speeds that are faster than all previous designs.

Increases folding capability by enabling the folder to produce a closed "double gatefold". This innovative pneumatic and electronic device operates at production speeds that are faster than all previous designs.

Increases folding capability by enabling the folder to produce a closed "double gatefold". This innovative pneumatic and electronic device operates at production speeds that are faster than all previous designs.

Increases folding capability by enabling the folder to produce a closed "double gatefold". This innovative pneumatic and electronic device operates at production speeds that are faster than all previous designs.

Increases folding capability by enabling the folder to produce a closed "double gatefold". This innovative pneumatic and electronic device operates at production speeds that are faster than all previous designs.

Increases folding capability by enabling the folder to produce a closed "double gatefold". This innovative pneumatic and electronic device operates at production speeds that are faster than all previous designs.

Increases folding capability by enabling the folder to produce a closed "double gatefold". This innovative pneumatic and electronic device operates at production speeds that are faster than all previous designs.

Increases folding capability by enabling the folder to produce a closed "double gatefold". This innovative pneumatic and electronic device operates at production speeds that are faster than all previous designs.

Increases folding capability by enabling the folder to produce a closed "double gatefold". This innovative pneumatic and electronic device operates at production speeds that are faster than all previous designs.

Increases folding capability by enabling the folder to produce a closed "double gatefold". This innovative pneumatic and electronic device operates at production speeds that are faster than all previous designs.

Increases folding capability by enabling the folder to produce a closed "double gatefold". This innovative pneumatic and electronic device operates at production speeds that are faster than all previous designs.

Increases folding capability by enabling the folder to produce a closed "double gatefold". This innovative pneumatic and electronic device operates at production speeds that are faster than all previous designs.

Increases folding capability by enabling the folder to produce a closed "double gatefold". This innovative pneumatic and electronic device operates at production speeds that are faster than all previous designs.

Increases folding capability by enabling the folder to produce a closed "double gatefold". This innovative pneumatic and electronic device operates at production speeds that are faster than all previous designs.

Increases folding capability by enabling the folder to produce a closed "double gatefold". This innovative pneumatic and electronic device operates at production speeds that are faster than all previous designs.

Increases folding capability by enabling the folder to produce a closed "double gatefold". This innovative pneumatic and electronic device operates at production speeds that are faster than all previous designs.

Increases folding capability by enabling the folder to produce a closed "double gatefold". This innovative pneumatic and electronic device operates at production speeds that are faster than all previous designs.

Increases folding capability by enabling the folder to produce a closed "double gatefold". This innovative pneumatic and electronic device operates at production speeds that are faster than all previous designs.

Increases folding capability by enabling the folder to produce a closed "double gatefold". This innovative pneumatic and electronic device operates at production speeds that are faster than all previous designs.

Increases folding capability by enabling the folder to produce a closed "double gatefold". This innovative pneumatic and electronic device operates at production speeds that are faster than all previous designs.

Increases folding capability by enabling the folder to produce a closed "double gatefold". This innovative pneumatic and electronic device operates at production speeds that are faster than all previous designs.

Increases folding capability by enabling the folder to produce a closed "double gatefold". This innovative pneumatic and electronic device operates at production speeds that are faster than all previous designs.

Increases folding capability by enabling the folder to produce a closed "double gatefold". This innovative pneumatic and electronic device operates at production speeds that are faster than all previous designs.

Increases folding capability by enabling the folder to produce a closed "double gatefold". This innovative pneumatic and electronic device operates at production speeds that are faster than all previous designs.

Increases folding capability by enabling the folder to produce a closed "double gatefold". This innovative pneumatic and electronic device operates at production speeds that are faster than all previous designs.

Increases folding capability by enabling the folder to produce a closed "double gatefold". This innovative pneumatic and electronic device operates at production speeds that are faster than all previous designs.

Increases folding capability by enabling the folder to produce a closed "double gatefold". This innovative pneumatic and electronic device operates at production speeds that are faster than all previous designs.

Increases folding capability by enabling the folder to produce a closed "double gatefold". This innovative pneumatic and electronic device operates at production speeds that are faster than all previous designs.

Increases folding capability by enabling the folder to produce a closed "double gatefold". This innovative pneumatic and electronic device operates at production speeds that are faster than all previous designs.

Increases folding capability by enabling the folder to produce a closed "double gatefold". This innovative pneumatic and electronic device operates at production speeds that are faster than all previous designs.

Increases folding capability by enabling the folder to produce a closed "double gatefold". This innovative pneumatic and electronic device operates at production speeds that are faster than all previous designs.

Increases folding capability by enabling the folder to produce a closed "double gatefold". This innovative pneumatic and electronic device operates at production speeds that are faster than all previous designs.

Increases folding capability by enabling the folder to produce a closed "double gatefold". This innovative pneumatic and electronic device operates at production speeds that are faster than all previous designs.

Increases folding capability by enabling the folder to produce a closed "double gatefold". This innovative pneumatic and electronic device operates at production speeds that are faster than all previous designs.

Increases folding capability by enabling the folder to produce a closed "double gatefold". This innovative pneumatic and electronic device operates at production speeds that are faster than all previous designs.

Increases folding capability by enabling the folder to produce a closed "double gatefold". This innovative pneumatic and electronic device operates at production speeds that are faster than all previous designs.

Increases folding capability by enabling the folder to produce a closed "double gatefold". This innovative pneumatic and electronic device operates at production speeds that are faster than all previous designs.

Increases folding capability by enabling the folder to produce a closed "double gatefold". This innovative pneumatic and electronic device operates at production speeds that are faster than all previous designs.

Increases folding capability by enabling the folder to produce a closed "double gatefold". This innovative pneumatic and electronic device operates at production speeds that are faster than all previous designs.

Increases folding capability by enabling the folder to produce a closed "double gatefold". This innovative pneumatic and electronic device operates at production speeds that are faster than all previous designs.

Increases folding capability by enabling the folder to produce a closed "double gatefold". This innovative pneumatic and electronic device operates at production speeds that are faster than all previous designs.

Increases folding capability by enabling the folder to produce a closed "double gatefold". This innovative pneumatic and electronic device operates at production speeds that are faster than all previous designs.

Increases folding capability by enabling the folder to produce a closed "double gatefold". This innovative pneumatic and electronic device operates at production speeds that are faster than all previous designs.

Increases folding capability by enabling the folder to produce a closed "double gatefold". This innovative pneumatic and electronic device operates at production speeds that are faster than all previous designs.

Increases folding capability by enabling the folder to produce a closed "double gatefold". This innovative pneumatic and electronic device operates at production speeds that are faster than all previous designs.

Increases folding capability by enabling the folder to produce a closed "double gatefold". This innovative pneumatic and electronic device operates at production speeds that are faster than all previous designs.

Increases folding capability by enabling the folder to produce a closed "double gatefold". This innovative pneumatic and electronic device operates at production speeds that are faster than all previous designs.

Increases folding capability by enabling the folder to produce a closed "double gatefold". This innovative pneumatic and electronic device operates at production speeds that are faster than all previous designs.

BAUM 32 Large Format Folder



Baum 32 Continuous Feed Folder
1st Station with 2-tiered Stacker

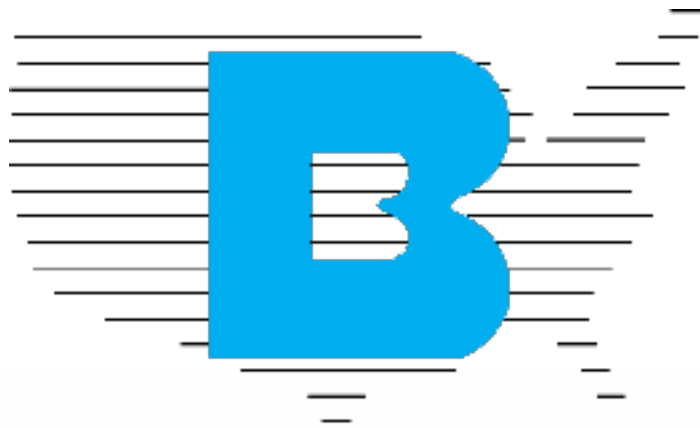

Baum 32 Continuous Feed Folder
with 8- and 16-page right angle
sections & two-tiered stacker

BAUM 32 Floor-Model Folder with Continuous Feeder, 8 & 16-Page Right Angles, K20 Knife Folder & Delivery Stacker

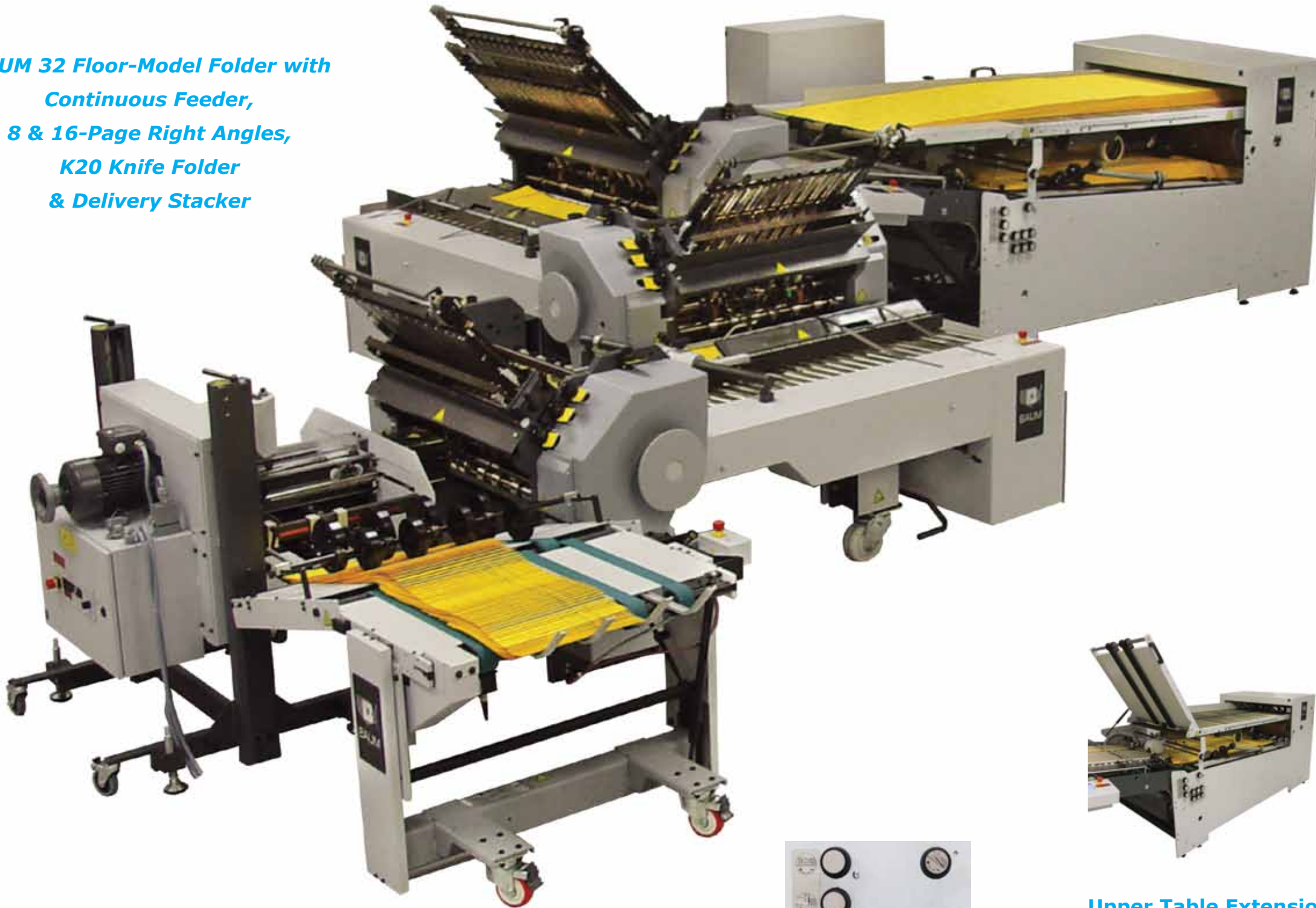

Spring-Loaded Feed Board

Maintains constant pressure on the sheets to keep them tight against the rear drum as they travel around to the lower table for consistent sheet shingling.



Roller Settings

Fast, accurate and easily accessible setups with micrometer adjustments to handle any stock, for any job. The "zero" reference lets the operator make adjustments and return back to the "zero" settings.



Upper Table Extension

A unique hinged design allows the table to be set at three different angled positions. This provides the operator convenient access to the vacuum wheel, and minimizes use of floor space.



Combination Fold Rolls

The Maxi-Grip fold roll technology is a combination of straight segment polyurethane rings and steel knurling, designed so that the polyurethane overlaps between adjacent folding rollers. This provides MAXIMUM GRIP and sheet travel control with non-marking capabilities. The Maxi-Grip folding rollers are available with soft polyurethane standard and optional hard polyurethane to accommodate a wide range of stocks with paper weights as low as 50gsm.

Crosscarrier

Non-marking cross carrier rollers are synchronously driven by toothed belts to provide non-slip drive of sheets. Combined with heavy-duty solid aluminum marble guide and solid steel bar paper guide for long wear and stability. Macro and micro-adjust are standard for placement of the guide.



Register

NEW PRISM Side Guide
Better sheet control is achieved with the superior profile of the Baum 32 Prism side guide. This precise profile guides both thin and thick stock weights in a unique and accurate profile much greater than simple sheet metal register guides.

Sealed Ball Bearings

No routine lubrication of the folder bearings saves time and money.

Positive Helical Gear Drive

A quiet, positive drive ensures tight, consistent folding without "soft" folds.



Front & Side Blow Control

A convenient and easy adjustment of air blow to the front of the sheets using three zones to increase or decrease the air volume independently where needed. Individual adjustment is also included for right and left side blow volume.



Side Blow

In addition to the advanced front air blow, the side blow provides portable air separation using simple adjustable floating paddle and side air tube design to place air blast where it is needed most for consistent feeding.



Vacuum Wheel

The vacuum control valve is located directly in the same housing as the vacuum feed wheel. This provides greater vacuum control and response time for consistent sheet feeding.

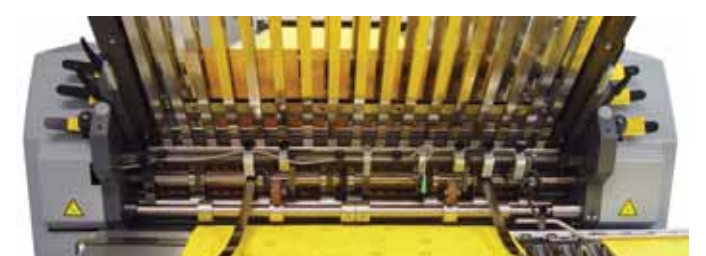

Slitter Shafts

The heavy-duty 35mm diameter slitter shaft removable design provides easy setup for perforating, scoring and slitting applications. Corrosion-free components are always easy to remove. A removable draw roll with adjustable exit wheels give firm control and placement of sheets. Optional lift kits are available for slitter shaft removal. Optional second set of slitter shafts is available.

Fold Plates

Ease of setup and precision folding are achieved using the swing deflector fold plates. All fold plates are heavy-duty fabricated construction with minimal surface contact with the sheets to allow the paper to travel effortlessly through the folder for smoother, faster operation. Micro-adjust, skew adjust and bottom lip adjust are standard features. Optional combination-design fold plates are available.

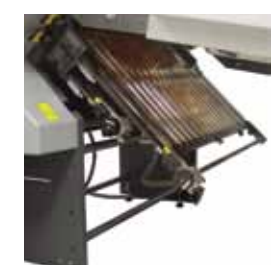
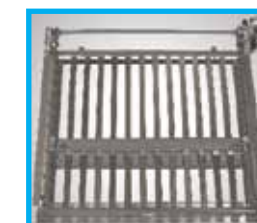

State-of-the-Art Controls

The Baum 32 operator control panel provides several exclusive features that improve productivity including:

- Learning Mode
- Machine Monitoring Modes
- Diagnostic Messages
- One-Sheet Setup Mode
- Counting Functions

Operator controls are provided at each folding section, including a convenient setup selection control button for test sheets.



Parallel, 1st station buckle fold units are available in 4 and 6 plate configurations
8-page, 2nd station buckle fold units are available in 2, 4, 6 and 8 plate configurations
16-page, 3rd station buckle fold units are available in 2 and 4 plate configurations
K20B knife folder can be utilized for 2nd, 3rd, or 4th station 32-page configurations



BAUM

1660 Campbell Road, Sidney Ohio 45365
Phone: 800/543-6107 or 937/492-1281, Fax: 937/492-7280
See us on the internet at www.baumfolder.com or e-mail baumfolder@baumfolder.com